



La Spaziale



La Spaziale S1 Mini Vivaldi II *Double Boiler Espresso Machine* Owner's Manual Rev. B

Updated on 2/7/09 to Describe Extreme Temperature Function
Also updated the water flow diagram and updated the Quick Setting Guide



S1 Mini Vivaldi II Owner's Manual

Table of Contents

1	Feature Overview	1
2	Reference Photos	2
3	Document Scope – Caveats and Clarifications	3
4	Basic Machine Operation	3
4.1	15 Amp or 20 Amp Operation (READ ME FIRST)	3
4.2	Initial Installation Before Connecting Power	4
4.3	Filling the Water Tank	5
4.4	Turning On and Heating the Machine	6
4.5	Espresso Brewing	7
4.6	Volumetric Dose Programming	7
4.7	Hot Water Delivery	8
4.8	Steam Delivery	8
4.9	Boiler Operational Modes	9
4.10	Espresso Group Water Temperature Regulation	11
4.10.1	Standard Temperature Adjustment	11
4.10.2	Offset Temperature Adjustment	11
4.10.3	Extreme Temperature Set Function	13
5	Alarm Handling	14
5.1	No Water in Tank	14
5.2	Coffee Group Water Dosing System Failure	14
5.3	Coffee Group Temperature Detection System Failure	14
5.4	Steam Boiler Temperature Detection System Failure	15
5.5	Damaged Group Heating Element Triac	15
5.6	Damaged Boiler Heating Element Triac	15
5.7	Boiler Automatic Refill System Failure	15
6	Connection Diagrams	16
6.1	Electrical Connection Diagram	16
6.2	Control Board Connection Diagram	17
6.3	Triac Board Connection Diagram	17
6.4	Control Panel Connection Diagram	18
6.5	Wiring Diagram Definitions	18
7	Mini VII Water Flow Diagram	19
8	Adjustments and Maintenance	19
8.1	Group Pressure Adjustment	19
8.2	External Mini VII Surface Cleaning	20
8.3	Routine Group Cleaning	20
9	Optional Accessories	21
10	Other LaSpaziale Mini VII Resources	24
11	Quick Setting Guide	25



S1 Mini Vivaldi II Owner's Manual

1 Feature Overview

- + Dual Boiler
- + Steam Boiler 1.2 liter
- + Comes with NEW .9 mm 4-Hole Steam Tip
- + Steam Boiler Element 1250 Watts
- + Group Boiler .45 liter
- + Group Boiler Element 800 Watts
- + Programmable Offset Differential
- + Swivel Stainless Steel Steam Arm
- + Two 53 mm Portafilters: One Single and One Double
- + Manual Fill 3 liter Water Tank
- + Vibratory Pump (Extremely Quiet)
- + Volumetric Dosing
- + Volumetric Dosing Adjustable Through Touch Pad
- + One Degree Group Temperature Adjustability Indicated by LED Display
- + Group Temperature Adjustable Through Touch Pad
- + Electronic Boiler Refill
- + Built-in Safety Thermostat
- + Built-in Safety Cut Out on Vibe Pump
- + Semiautomatic Hot Water Delivery
- + Lever Steam Valve same as La Spaziale S5 Commercial Machines.
- + Fault Diagnosis Alarms
- + Dual Manometer
- + OPTIONAL Pre Infusion Chamber
- + OPTIONAL 7 Day Programmable Timer
- + OPTIONAL No Burn Steam Arm
- + OPTIONAL longer La Spaziale steam arm
- + OPTIONAL Drain Kit
- + Color Black or Red
- + 110 volt
- + Functions in either 15 amp or 20 amp
- + ETL Sanitation Listed (Conforms to ANSI/NSF STD 4)
- + c ETL us Listed (Conforms to UL STD 197 Certified to CAN/CSA STD C22.2 NO. 109)



S1 Mini Vivaldi II Owner's Manual

2 Reference Photos

These numbered photos will be referenced throughout the document; i.e. (13)





S1 Mini Vivaldi II Owner's Manual

FIGURE 1 – Indicator Lights and Control Buttons

Label	Function	Label	Function	Label	Function	Label	Function
1	Drip Tray	9	Control Panel	17	94°C Lamp	25	Double Cup Button
2	Steam Arm	10	Group	18	95°C Lamp	26	Boiler Button
3	Rubber Feet	11	Portafilter Handle	19	96°C Lamp	27	On/Off Button
4	Water Tank	12	Drip Tray Grate	20	97°C Lamp	28	Hot Water Outlet
5	Side Panels	13	Boiler Lamp	21	Empty Water Tank	29	Steam Pressure Gauge
6	Steam Lever	14	91°C Lamp	22	On/Standby Lamp	30	Group Pressure Gauge
7	Cup Warming Tray	15	92°C Lamp	23	Hot Water Button		
8	Splash Panel	16	93°C Lamp	24	Single Cup Button		

3 Document Scope – Caveats and Clarifications

This manual includes material that both duplicates and enhances the official LaSpaziale S1 Mini Vivaldi Instruction Manual in key areas. However, it does not duplicate the detailed and very important information covering machine certifications or ratings nor does it repeat all the warning and safety information contained on the “lawyer” pages. That information, as contained in LaSpaziale Instruction Manual Part # LSC 014-UK Rev.00 or later, is considered included in this document by reference.

The official LaSpaziale S1 Mini Manual covers the Mini Vivaldi I and the Mini Vivaldi II plus one option not currently offered or required in the consumer market. That option, as well as material intended specifically for the Mini Vivaldi I, has been omitted from this document.

This document solely covers the S1 Mini Vivaldi II plus options available and supported by Chris Coffee Service and/or other vendors supplied by Chris Coffee Service through its exclusive distribution agreements with La Spaziale S.p.A.

4 Basic Machine Operation

(**BOLD** = lamps, **Reverse** = buttons, numbers in parentheses reference to above table)

4.1 15 Amp or 20 Amp Operation (READ ME FIRST)

Please read this section first, especially if you purchased the 20A version of the LaSpaziale VII Mini but do not currently have an available 20A outlet.

The LaSpaziale Mini VII can be purchased in 15A and 20A versions. In actuality, they are both identical machines. There is an internal switch that selects the operating mode and they have different power cords installed. The power cord is the easiest way to tell which version you have. The 15A Mini VII has a standard 3-prong AC plug with two parallel blades and a round ground pin. The 20A Mini VII has a 3-prong plug with two



S1 Mini Vivaldi II Owner's Manual

perpendicular blades and a round ground pin. The 20A version therefore requires a 20A circuit which has a special 20A outlet which accepts the 20A plug.

Most modern kitchens have 20A circuits. However, they often do not use 20A outlets because multiple outlets may be on the same 20A circuit. If you have a 20A circuit with a 20A outlet this most likely means that outlet has its own dedicated 20A circuit and is safe to use with the Mini VII. A 20A circuit with normal 15A outlets probably means that multiple kitchen outlets are on the one 20A circuit. Often this means the refrigerator outlet. 20A Mini VII owners should contact their electrician if unsure how to proceed.

The internal switch which places the Mini VII in 15A mode does so by never allowing the group boiler and the steam boiler to operate at the same time. When the thermostats for both boilers try to turn on at the same time, the group boiler always has precedence, and then the steam boiler operates in sequential fashion. A number of 15A Mini VII owners note that they see little operational effect when running in this mode.

The 20A Mini VII allows both boilers to operate simultaneously. HOWEVER, it is possible to place the 20A Mini VII into 15A mode by removing the top cover from the machine and flipping the internal mode switch. This is often referred to as "Economy Mode".

Economy mode is a great option for those that really want the 20A machine but that do not currently have a 20A circuit. In addition to flipping the mode switch from 20A to 15A operation, this will require swapping out your standard 15A outlet with a 20A outlet. These are readily available from most hardware stores. For a more temporary solution there is an alternative such as this adapter cable available from Chris Coffee Service: <http://www.chriscoffee.com/products/home/espressoaccs/20t015adaptorplug>. It is also available elsewhere or you can make your own with a quick trip to your local hardware store.



4.2 Initial Installation Before Connecting Power

After removing the Mini VII from its packing carton and setting it on the counter, check for additional installation instructions that may be included. You should also have all the accessories shown in the photo below plus a rubber backflush disk (not shown).



S1 Mini Vivaldi II Owner's Manual



Tip the Mini VII on its side. Twist all four rubber feet (3) hand tight as they may vibrate loose during shipping. While performing that task, use a screwdriver to ensure that the four screws on the bottom (two on each side between the rubber feet) which fasten the two side panels (5) to the chassis bottom are tight. These steps will help ensure the quietest possible operation of your Mini VII.

Important Tip: Your Mini VII dealer may request that you check that your water hardness is below a certain level to ensure long life and trouble free operation. Hardness test strips may be included for this purpose. If your water fails this test, contact your Mini VII dealer and discuss the available options. This test should be done before using your machine. Water over 3 grains of hardness needs to be softened or else consider using bottle water. Hard water will require frequent descaling which is not a trivial procedure on this machine. Over time use of very hard water could result in the need to replace the steam boiler heater element. Since the VII Mini has a sealed boiler, replacement of the entire boiler is required. This is not an inexpensive repair. Be forewarned. Use soft water.

4.3 Filling the Water Tank

- 1) Remove the drip tray (1)
- 2) Remove the water tank (4) and fill with soft water to ensure against mineral buildup in your boilers
- 3) Replace the water tank (4) and the drip tray (1)
- 4) Insert the plug into the 110V AC socket, the **On/STBY** light (22) starts flashing. (Stand-by mode).
- 5) Press the **ON / OFF** (27) and **Hot Water** (23) buttons simultaneously. During this stage, the control lights **EMPTY** and **On/STBY** (22) blink while the pump runs



S1 Mini Vivaldi II Owner's Manual

- 6) Once you see water coming from the group (10), release both buttons. The unit is now in Standby mode with the **On/STBY** light blinking. You have now primed the pump and filled both boilers with water.

Important Tip: *The above procedure is only required on the initial use of the machine or any time when starting up with empty boilers such as after storage, boiler clean out, shipment, etc. or any time the boilers have previously been drained. Otherwise, once this procedure is performed once, it is only necessary to turn the machine on using the **ON/OFF** (27) button. It is NOT required to perform the above procedure each time the water tank is refilled.*



4.4 Turning On and Heating the Machine

- 1) Place the desired coffee basket (Single or Double) into one of the portafilter handles and attach it to the group.
- 2) Insert the plug into the 110V AC socket, the **On/STBY** light (22) starts flashing. (Stand-by mode).
- 3) Press the **ON / OFF** (27) and button and keep it pressed for about 3 seconds, the green **On/STBY** light (22) changes from flashing to steady indicating the machine is ON. At the same time the lights from (14) to (21) turn on steadily for about a second (indicating power on test mode).



S1 Mini Vivaldi II Owner's Manual

- 4) The light corresponding to the set temperature starts flashing to indicate that the group is heating and the automatic boiler refill starts until the water level preset by the manufacturer is reached.
- 5) Once the filling process is finished, the **BOILER** light (13) starts flashing to indicate that the boiler is heating. However, after first switching on, the boiler doesn't work until the group has reached the set temperature.
- 6) Fasten the portafilter handle (11) to the brewing group (10).
- 7) Wait until the set temperature is reached, by checking that the lights on the control panel (9) gradually turn on as the temperature rises. The visualization starts as soon as the temperature reaches 91°C (turning on of light 14) and continues until the machine has reached its operating temperature (light from flashing to fixed).
- 8) When the group has reached the set temperature, the boiler heating starts (**BOILER** light (13) flashing), once it reaches the set temperature the light becomes fixed.
- 9) Every time the group temperature or the boiler temperature drops under the set value, the respective light starts flashing (heating phase) until the set temperature is reached.
- 10) The machine is now ready.

Important Tip: To activate and deactivate the boiler mode press the **BOILER (26) button. When the unit is turned off, then back on or even unplugged, then plugged back in, the Mini VII will remember the last state of the Boiler mode.**

When the boiler is turned off, it is impossible to use hot water for infusions or steam delivery.

4.5 Espresso Brewing

1. Unfasten the portafilter handle (11) from the brewing group (10) and insert the filter for one or Double Cups. Fill it with ground coffee, making sure not to leave coffee powder on the upper edge of the portafilter handle (11), and press it with the suitable coffee tamper provided.
2. Firmly attach the portafilter handle (11) to the brewing group (10).
3. Place one or Double Cups under the portafilter handle (11).
4. Press the button corresponding to Single Cup (24) if you want to make one coffee or Double Cups (25) to start the delivery. Once the desired quantity of coffee programmed is reached, the delivery automatically stops.

4.6 Volumetric Dose Programming

The programmable volumetric dosing feature allows programming of the **Single Cup** (24) and **Double Cup** (25) buttons to dispense whatever quantities of espresso the user desires. Their use for single cup and double cup quantities is merely a suggestion. Many users only pull double shots and program the double shot button for 1.5-2.0oz for that purpose. Then they program the **Single Cup** button for a larger



S1 Mini Vivaldi II Owner's Manual

amount for use in flushing the portafilter basket and/or the group between shots. The beauty of the programmable dosing feature is that the machine owner can be creative. The following are the instructions for programming each button assuming they are being used for single and double shots.

1. With the machine on, press the **ON/OFF** (27) button and keep it pressed for about 3 seconds; the control light (22) and the one indicating the set temperature start flashing.
2. Insert the single cup basket into the portafilter handle (11) and fill it with 7-8g of ground coffee making sure not to leave coffee powder on the upper edge of the portafilter handle, and press it with the included plastic tamper or, more optimally, a high quality 53mm coffee tamper.
3. Fasten the portafilter handle (11) to the brewing group (10), placing a cup under the portafilter handle.
4. By pressing the **Single Cup** button (24) the delivery starts and the lights 14-15-16 turn on to show that the one shot espresso dose is being programmed.
5. When the coffee inside the cup has reached the desired quantity, again press the button (24) to stop the delivery.
6. You automatically return to the initial visualization.
7. Repeat the previous steps above using the **Double Cup** button (25) making sure you change the filter inside the portafilter handle (11) to the double shot basket and fill it with 14-16g of espresso first.

4.7 Hot Water Delivery

(only possible with the boiler turned on, **BOILER** light 13 on)

1. Place the pitcher below the hot water output (28):
2. Press the **Hot Water** delivery push-button (23).
3. The hot water delivery starts.
4. Once the desired quantity is reached, stop the delivery by pressing the **Hot Water** button (23) again.

Important Tip: The steam/hot water boiler on the V2 Mini is not very large. When using it for hot water, it is suggested that no more than ~6oz be removed at a time and then let the unit refill the boiler before using again. Otherwise, you run the risk of exposing the steam boiler heater element while it is powered up and possibly damaging it.

4.8 Steam Delivery

(only possible with the boiler turned on, light 13 turned on)

1. Insert the steam wand (2) in the pitcher containing the drink to be heated.
2. Push the steam lever (6) up, regulating the steam flow according to the need.
3. At the end of the heating phase of the drink, stop the steam delivery by pulling the steam lever (6) all the way down.



S1 Mini Vivaldi II Owner's Manual

4. Remove the pitcher from the steam wand (2) and wipe the steam wand and tip immediately with a clean, damp sponge in order to remove all residue of the heated drink.
5. NOTE: The steam lever (6) will remain in the all the way up position when released. However, if released in any other position, the lever will automatically drop to the off position.

Important Tip: Do not engage the steam lever(6) before placing the steam wand (2) inside the pitcher, in order to avoid burns.

4.9 Boiler Operational Modes

There are three possible operational modes of the two boilers in the LaSpaziale Mini VII 20A model:

- ✚ Both boilers are completely independent, turning on and off according to the needs of each. Both can be on at the same time. This is the default mode with the BOILER enables and 20A mode selected using the internal 15A/20A switch.
- ✚ The **BOILER** button can toggle the Boiler on and off. This mode is useful for those that only drink espresso and do not need steam or hot water and want to conserve energy. This can be used to keep the boiler off regardless of whether the machine is running in 15A or 20A mode.

Important Tip: The state of the **BOILER** button is kept in memory and is maintained through On/Stby cycles, when the unit is unplugged, or if there is a power failure.

- ✚ The Mini VII can also be switched into Economy (15A) mode. In this mode, only one boiler can be on at a time. The Mini VII automatically controls which is on according to demand with preference going to the group boiler. This is useful for those owning the 20A model but lacking a 20A circuit. How to do this is described below.

Turning the Steam/Hot Water Boiler On and Off

1. The Mini VII must be in ON mode, not Standby for all operations below.
2. Momentarily press the **BOILER** button
3. The **BOILER** lamp turns off. Neither steam nor hot water is available.
Note: if you turn the Mini VII Off then On again, or if power is removed and restored to the Mini VII, the Boiler returns to the On state.
4. Momentarily press the **BOILER** button again.
5. The **BOILER** lamp is on (or blinking). Steam and hot water are available.



S1 Mini Vivaldi II Owner's Manual

Turning Economy (15A Mode) On and Off

1. The Mini VII must be unplugged and allowed to cool down first.
2. Remove any cups from the cup warming tray (7)
3. Remove the single screw in the front middle of the cup warming tray (7) as shown in the photo below



4. From the front of the machine look down into the top of the machine. In the right rear of the machine you will see a toggle switch with its positions labeled 15 and 20. Reach down with the same screwdriver you used to remove the cup warming tray and flip the switch to the desired position.

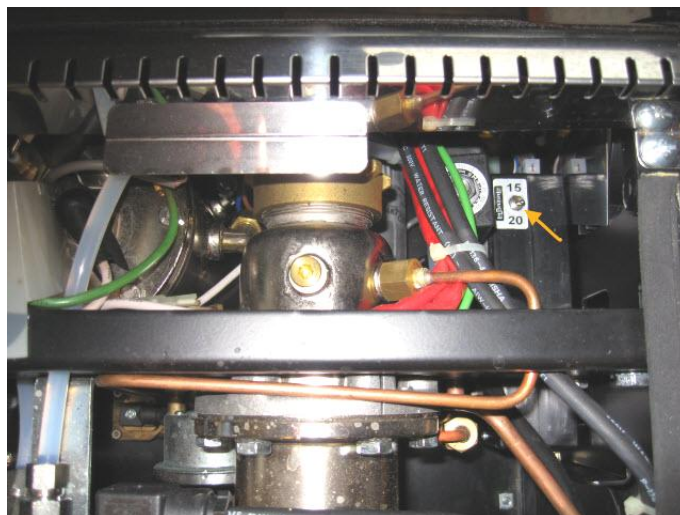



S1 Mini Vivaldi II Owner's Manual

4.10 Espresso Group Water Temperature Regulation

4.10.1 Standard Temperature Adjustment

1. When the machine is On (**ON/STBY** solid green), press the button **ON/OFF** (27) and keep it pressed for 3 seconds, the control light (22) and the one concerning the set temperature start flashing. For example, if the set temperature is 95°C, light (18) starts flashing.
2. In order to change the operating temperature, press and release the **Hot Water** button (23); every press of the button corresponds an increase of the temperature of 1°C (with the flashing of the corresponding light). When the maximum temperature of 97°C (20) is reached, the selection restarts from the minimum temperature of 91°C (14) (cyclic mode).
3. Once you choose the desired temperature, in order to lock in this value, press the **ON/OFF** (27) button, the machine will then go back to its normal functioning.

The value of the operating temperature of the machine is easily changed in order to improve the final result in the cup depending on the coffee blend used and the user's personal preference.

4.10.2 Offset Temperature Adjustment

What Does Temperature Offset Do? / How Do I Use it?

The Vivaldi group design exhibits a temperature drop between where the group boiler temperature probe is located and where the hot water exits the group. Consequently, the temperature setting shown by the temperature lamps on the front panel may differ from the water temperature at the group. Ideally, most users would prefer that the temperature indicated by the temperate lamps exactly matches the water temperature exiting the group. LaSpaziale has partially accounted for this in its basic design. However, there are too many machine to machine electrical and mechanical variances for this to be completely effective. That's where the temperature offset comes in. The programmable temperature offset allows a user with accurate group temperature measuring equipment to enter an offset in the range of $\pm 8^{\circ}\text{C}$ (for extended offset option or 0 to -8°C for standard offset option) in order to allow their machines temperature lamps to exactly match the water temperature exiting the group.

Those purchasing new machines from Chris Coffee Service have had the temperature offset professionally programmed used a Scace device. However, for those obtaining the expanded offset capability via an upgrade, it is recommended that you note the current offset prior to upgrading and then duplicate that offset using the instructions below. If you do not know how to tell what your current offset is, you can find out by entering the temperature offset mode and then following instructions in paragraph 4.10.2.



S1 Mini Vivaldi II Owner's Manual

4.10.2.1 Extended Temperature Offset Adjustment

Start with the machine in Standby mode (**ON/STBY** blinking green). Press and hold the **BOILER** button for about 10 seconds until the **Boiler** light and the **ON/STBY** light start flashing. You are now in the temperature offset programming mode.

To enter a positive temperature offset between 0°C and +8°C push the **Single Cup** button. Each press will change the offset by +1°C. An offset of 0°C is designated by all temperature lamps off. A +8°C offset is designated by all temperature lamps plus **ECON** on (Low Water on Mini VII Mini). If your positive offset is more than you wish, each press of the **Double Cup** button changes the offset by -1°C.

To enter a negative temperature offset between 0°C and -8°C mode push the **Double Cup** button. Each press will change the offset by -1°C. An offset of 0°C is designated by all temperature lamps off. A -8°C offset is designated by all temperature lamps plus **EMPTY** on. If your negative offset is more than you wish, each press of the **Single Cup** button changes the offset by +1°C.

How Do I Tell If My Current Offset is Negative or Positive?

Example: You enter Offset Programming mode and see that three lamps are on. This can indicate either ±3°C. Which is it? Since each press of the **Double Cup** button changes the offset by -1°C, press it and see what happens. There will either be two or four lamps lit. If four lamps are lit the offset must have been -3°C since pressing **Double Cup** always changes the setting by -1°C with each press. If two lamps are lit the offset was +3°C. By pressing **Double Cup** the offset has changed to +2°C.

-8 -7 -6 -5 -4 -3 -2 -1 0 +1 +2 +3 +4 +5 +6 +7 +8 °C Offset

-----→ **Single Cup** Button

←----- **Double Cup** Button

Note that neither the **Single Cup** nor the **Double Cup** button presses wrap around when they reach the limit of their range. Once you get to +8°C additional presses of the **Single Cup** button do nothing. Same with the **Double Cup** button once -8°C is reached.



S1 Mini Vivaldi II Owner's Manual

See table below:

Offset	91°C Lamp	92°C Lamp	93°C Lamp	94°C Lamp	95°C Lamp	96°C Lamp	97°C Lamp	EMPTY Lamp
0°C	Off	Off	Off	Off	Off	Off	Off	Off
±1°C	On	Off	Off	Off	Off	Off	Off	Off
±2°C	On	On	Off	Off	Off	Off	Off	Off
±3°C	On	On	On	Off	Off	Off	Off	Off
±4°C	On	On	On	On	Off	Off	Off	Off
±5°C	On	On	On	On	On	Off	Off	Off
±6°C	On	On	On	On	On	On	Off	Off
±7°C	On	On	On	On	On	On	On	Off
±8°C	On	On	On	On	On	On	On	On

4.10.3 Extreme Temperature Set Function

Standard temperature programming described in section 4.10.1 allows a range from 91°C to 97°C in 1°C increments. There may be times when the user desires a temperature outside of this range. While the Offset mode described in section 4.10.2 could be used for this purpose, it is best to use the offset as intended. Once set properly, the offset should be left alone. Instead, the VII Mini includes a mode specifically for use in extending the temperature range above 97°C or below 91°C up to a max of 3°C. While the ability to extend the temperature above 97°C is of limited use, there are some types of coffee whose flavor is optimum in the 88°C to 90°C range.

Note that the method below only works if the master temperature is set to either 91°C or 97°C. If the temperature is set to 91°C you can only use the instructions below to lower the temperature by 1°C, 2°C, or 3°C. If the temperature is set to 97°C you can only use the instructions below to raise the temperature by 1°C, 2°C, or 3°C. Consequently you must use the instructions provided in section 4.10.1 to set the master temperature to 91°C or 97°C BEFORE using the instructions below. If this is not done, the instructions below for entering the Extreme Temperature Set mode will work as described, but once in that mode attempting to a raise or lower the temperature has no effect.

Instructions for programming this mode AFTER setting the master temperature to 91°C or 97°C are:

- Start with the machine in Standby mode (**ON/STBY** light flashing).
- Press and hold the **Two Cup** button for ~3 seconds until lights 94°C (17) and 95°C(18) come on indicating that the Extreme Temperature Function setting mode is active.



S1 Mini Vivaldi II Owner's Manual

- If you start with the master temperature set to 97°C, each time that the **Hot Water** button is pressed, lights 96°C (19), 97°C (20), and Tank Low (21) will switch on in succession. Each light indicates a 1°C increase. All three lights on = 100°C.
- If you start with the master temperature set to 91°C, each time that the **One Cup** button is pressed, lights 93°C (16), 92°C (15), and 91°C (14) will switch on in succession. Each light indicates a 1°C decrease. All three lights on = 88°C.
- Press the **Two Cup** button again to exit Extreme Temperature set mode and return back to Standby mode

Notes:

1. You can simultaneously have these Extreme Temperature settings on both the 91 °C and the 97 °C buttons. However, you have to perform the above steps twice - once with the master temperature set to 91°C before following these instructions and again with the master temperature set to 97 °C.
2. Once you change the temperature of the 91°C and/or 97°C buttons, pressing those buttons will yield the reprogrammed temperature until changed again.

5 Alarm Handling

The Mini VII uses computerized sensors to robustly handle Mini VII device malfunctions. There are two types of alarms the Mini VII can generate:

Blocking Alarms – these are the most serious. The VII will turn itself Off and display the alarm codes noted below when one of these alarms occurs.

Non-Blocking Alarms – These are informational only and, while they do represent an error condition, the machine will continue to function.

5.1 No Water in Tank

When the tank (4) is out of water the red **EMPTY** light (21) comes on and remains on until at least 1liter of water is added. The tank can hold up to 3 liters.

5.2 Coffee Group Water Dosing System Failure

When the flow meter isn't working properly or when the coffee grind is too fine, this is indicated by the turning on of the lights 14-15-16; if you are making one coffee dose, and the lights 17-18-19 if you are making two coffee doses. This is a non-blocking alarm. This alarm is actually useful when back flushing as an indication of when to turn off the pump and allow the 3-way valve to operate.

5.3 Coffee Group Temperature Detection System Failure

This alarm is a blocking one, and occurs when the temperature probe of the group is in short circuit (temperature >145°C) or is in open circuit (disconnected) condition (temperature <60°C). The lights 20-21 turn on.



S1 Mini Vivaldi II Owner's Manual

If the group water temperature does not exceed 60°C within 5 minutes of turning the unit on, this alarm will also occur.

Turn off the Mini V2 and request service.

5.4 Steam Boiler Temperature Detection System Failure

(only with the boiler turned on)

This is a blocking alarm and occurs when the temperature probe of the boiler is in short circuit (temperature >145°C) or it is in open circuit (disconnected) condition (temperature <60°C). The lights 19-20-21 turn on.

The alarm can be temporarily cleared by turning the boiler off (Press **BOILER** (26) button.) Eventually you will need to turn off the Mini V2 and request service.

5.5 Damaged Group Heating Element Triac

This alarm is a blocking one, and occurs when the group triac always remains in conduction (temperature >140°C). The lights 20-21 are flashing.

Turn off the Mini V2 and request service.

5.6 Damaged Boiler Heating Element Triac

(only with the boiler turned on)

This alarm is a blocking one, and occurs when the boiler triac always remains in conduction (temperature >140°C). The lights 19-20-21 are flashing.

Turn off the Mini V2 and request service.

5.7 Boiler Automatic Refill System Failure

(only with the boiler turned on)

This is a blocking alarm which is signaled by blinking of the **Boiler** (13) light. If the pump runs for more than 1 minute attempted to refill the boiler without the controller circuit receiving a boiler full signal, this alarm is triggered.

This alarm can be temporarily cancelled by pressing the **BOILER** (26) button to turn off the boiler. The Mini VII can be operated with the steam boiler off until repairs to the boiler function occur.

Factoid: A triac is a device to which a small DC control voltage can be applied in order to turn on a large AC current source. One is used for each boiler in the VII. Think of a triac as a solid state semiconductor equivalent of an electro-mechanical relay. TRIAC is an acronym for Triode for Alternating Current.

6 Connection Diagrams

6.1 Electrical Connection Diagram

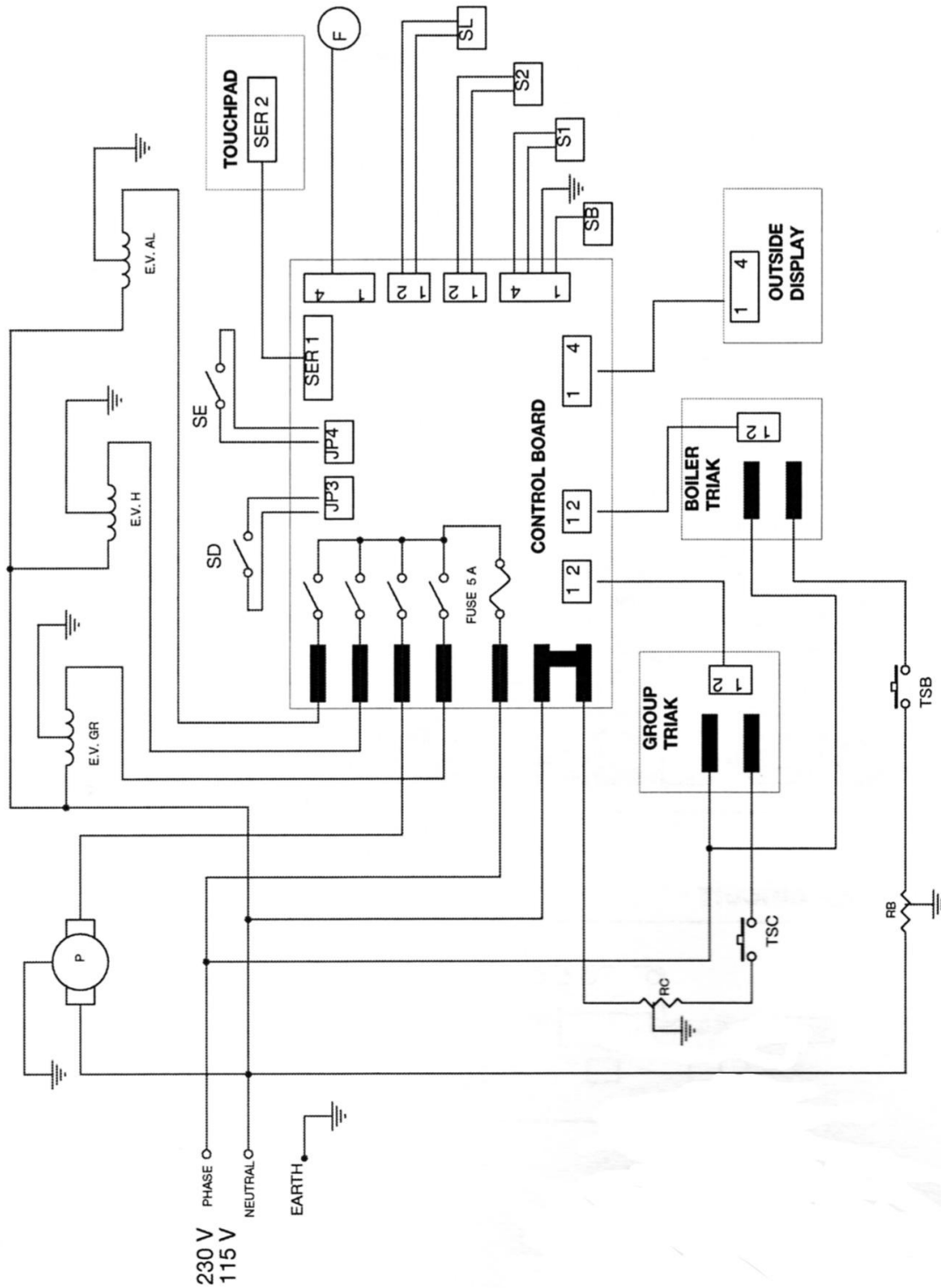

S1 Mini Vivaldi II Owner's Manual

6.2 Control Board Connection Diagram

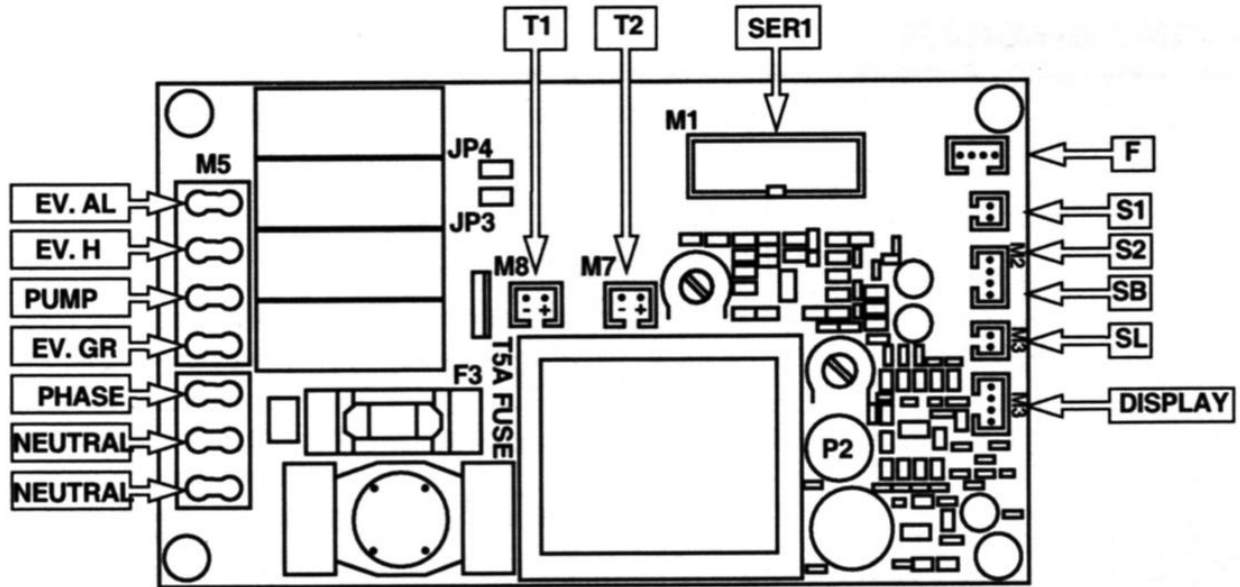

6.3 Triac Board Connection Diagram

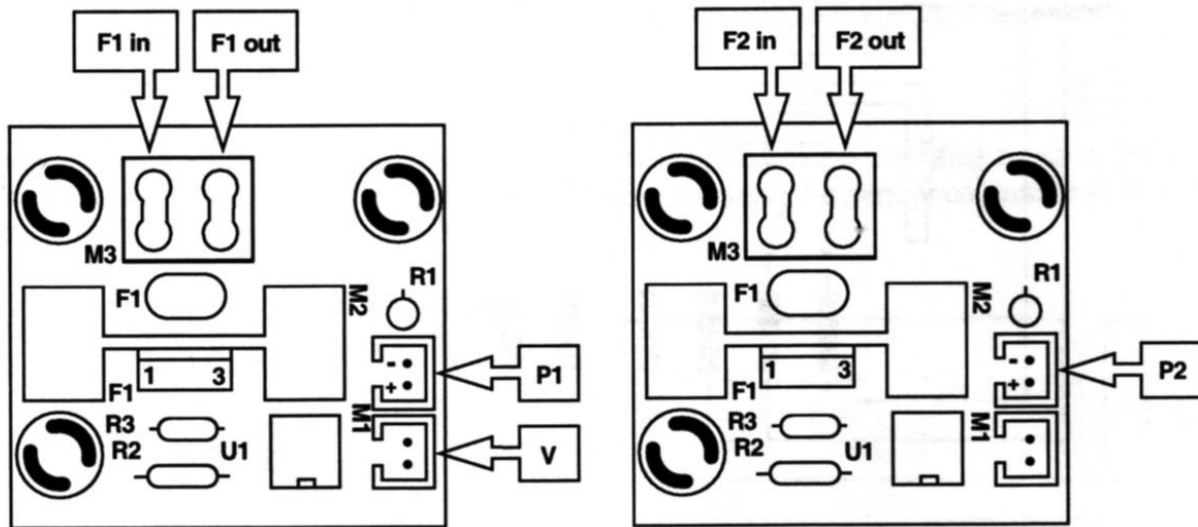

BOILER TRIAC BD

GROUP TRIAC BD

(Cooling Fan is below this board and runs only when boiler is heating)

S1 Mini Vivaldi II Owner's Manual

6.4 Control Panel Connection Diagram

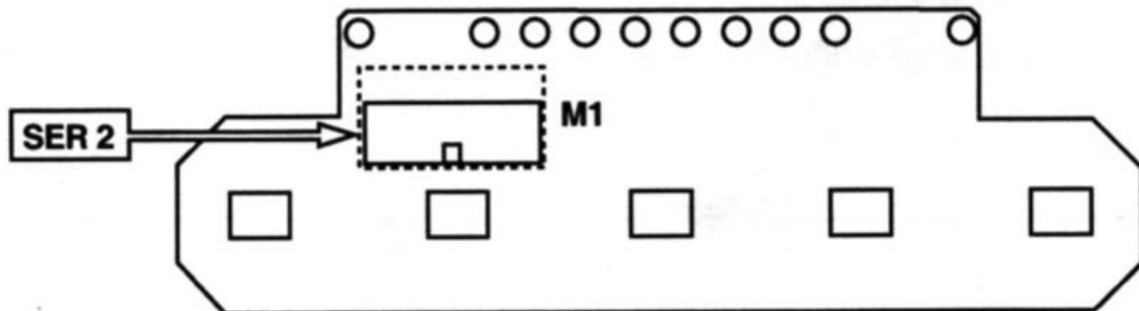

6.5 Wiring Diagram Definitions

EV GR	Coffee brewing group solenoid valve
EV H	Hot water delivery solenoid valve
EV AL	Automatic refill system solenoid valve
T1	Connection on control board of the triac that feeds the boiler heating element
T2	Connection on control board of the triac that feeds the group heating element
P1	Connection of the control board on the triac that feeds the boiler heating element
P2	Connection of the control board on the triac that feeds the group heating element
SER 1	Connection control panel on control board
SER 2	Connection control board on control panel
F	Flow meter
F1 in	Phase inlet into the triac that feeds the boiler heating element
F1 out	Phase outlet from the triac that feeds the boiler heating element
F2 in	Phase inlet into the triac that feeds the group heating element
F2 out	Phase outlet from the triac that feeds the group heating element
S1	Boiler temperature probe
S2	Brewing group temperature probe
SL	Container water level sensor
SB	Boiler Water Level Control
Display	Cable Connector for Optional Timer Module
V	Ventilator connection (steam boiler triac cooling fan)
P	Vibe Pump
RC	Heating element brewing group
TSC	Safety thermostat for brewing group heating element
RB	Boiler heating element
TSB	Safety thermostat for boiler heating element
JP4	15/20A Mode Selector Connection
JP3	Optional Timer Switch Connector
SD	Optional Timer On/Off Switch
SE	15/20A Mode Switch

7 Mini VII Water Flow Diagram

The information below is provided strictly as a reference for Mini VII owners who are curious about the function of their Mini VII Dual Boiler design.

LaSpaziale V2 Mini Water Flow Diagram

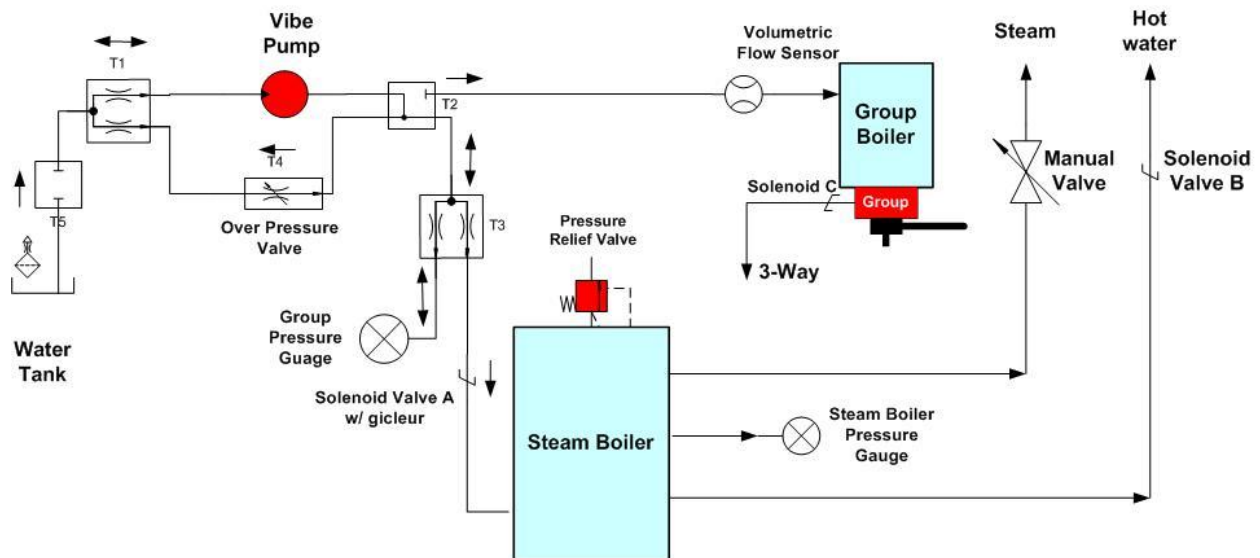

8 Adjustments and Maintenance

8.1 Group Pressure Adjustment

Conventional espresso guidelines call for group pressure in the range of 8.25-9.5 Bars. This is normally set to 9.0 bar prior to shipment. Should you wish to try a lower pressure or, if adjustments are required at some future time, use the procedure documented below.

- 1) Pull out the drip tray and set it aside
- 2) Remove the two screws holding the chrome front splash panel in place. (The panel that the pressure gauge protrudes through.)
- 3) With the panel removed you will see the adjustment nut shown in the photo below.
- 4) Insert the portafilter with the rubber disk inserted or using a "blind basket", the same as you would do for backflushing.
- 5) Press the One Cup or Two Cup Button.
- 6) Use either the correct metric box wrench or an adjustable wrench to adjust the group pressure as noted on the group pressure gauge to your desired value. Turn right to increase pressure, left to decrease pressure.



S1 Mini Vivaldi II Owner's Manual

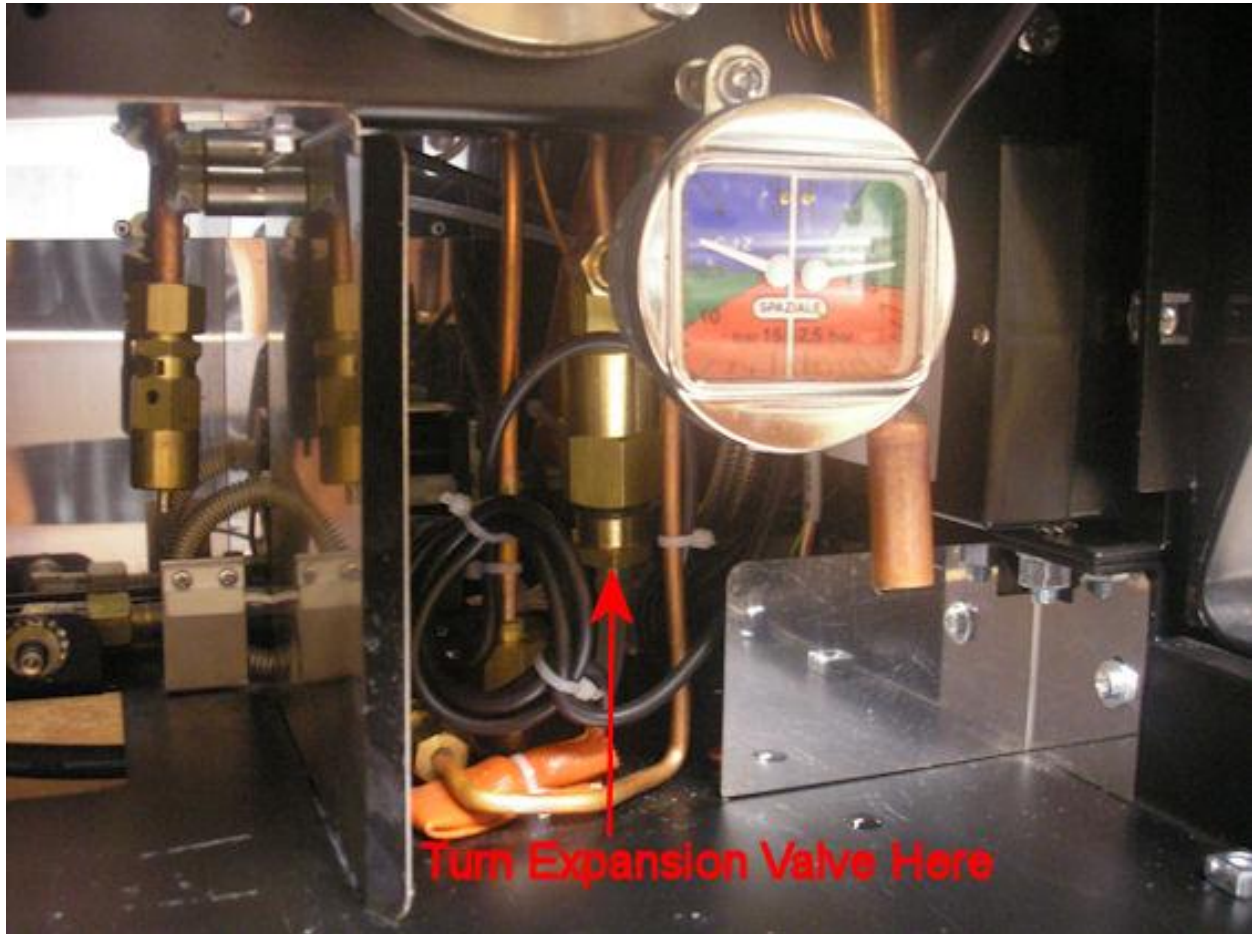

8.2 External Mini VII Surface Cleaning

Use a damp sponge and wipe dry with a soft cloth. Alternately, window cleaner wiped off with a dry soft cloth works well.

8.3 Routine Group Cleaning The Official LaSpaziale Method™

The extra pair of shower screens was not included with your Mini VII so you'd have an extra set. They are included as part of LaSpaziale's recommended cleaning regimen which is targeted at light commercial use where there is no time for a complete detergent based back flush routine. The reason for LaSpaziale's double shower screen arrangement is to trap grounds between the screens so that the 3-way valve rarely, if ever, needs a detergent cleaning.

- ✚ With the Mini VII on and fully heated, use the included key wrench to remove the shower screen bolt.
- ✚ Drop out the two screens and the dispersion disk.



S1 Mini Vivaldi II Owner's Manual

- ✦ Use the included plastic handled wire brush to quickly scrub the group head while water is running through the group to flush out the particles. (This is why the long handled brush - to keep your hands away from hot water.)
- ✦ Also, give the dispersion disk a quick scrub.
- ✦ Reassemble using the other set of screens.
- ✦ Soak the original set of screens in Cafiza, Joe Glo, or similar detergent, scrub, rinse, and put away for next time.

The Way Most Mini V2 Users Actually Do It:

As noted above the official LaSpaziale method was developed assuming the machine is in light commercial use. This is certainly not the target market for the Mini V2. Here is how most users clean their coffee group (once every 3-4 weeks is enough):

- ✦ Start with the basic procedure above, though most folks use something like a Pallo brush rather than the wire brush that came with the machine for the 3rd step. Once the clean screens and dispersion disk are back in the machine perform the following steps.
- ✦ Using 1/3 tsp Cafiza, Joe Glo, or similar detergent every 2-4 weeks is plenty for home use. Backflush the S1 Vivaldi II Mini more often with plain water.
- ✦ Place the backflush disk in the single basket with 1/3 tsp of Cafiza powder.
- ✦ Press the single cup button. Wait 5-10 seconds.
- ✦ Press the single cup button again to stop the pump which automatically engages the 3-way valve.
- ✦ Perform the above cycle 5 times waiting about 30 seconds between each cycle.
- ✦ Then rinse the remaining detergent from the basket and replace the portafilter with the backflush disk still installed.
- ✦ Backflush for 5 more cycles to rinse the remaining residue from the group and 3-way valve.
- ✦ Remove the backflush disk, make shot of espresso and throw it out.

Important Tip: To maximize the effectiveness of the cleaning process and minimize how often a detergent cleaning is required, after every series of shots is pulled, run a shot with the PF remove. Scrub the screens and around the gasket with a Pallo brush while the hot water is exiting the group. This will flush most of the grounds and sediment into the drip tray.

9 Optional Accessories

These can be ordered and installation arranged at the time you order the Mini V2. In addition, they can be ordered later and self-installed if you are the handy with simple metric tools.

Pre-Infusion Chamber



S1 Mini Vivaldi II Owner's Manual

Click the link below for the Installation Guide:

<http://s1cafe.com/s1v2/images/LaSpazialeProgressionPreinfusionInstallationManual.pdf>



Drain Kit



Programmable Timer

Use this link to download the installation and programming guide for this device:

<http://s1cafe.com/s1v2/images/Vivaldi%20Timer%20Instructions.pdf>



S1 Mini Vivaldi II Owner's Manual



Longer Steam Arm (Shown next to stock arm)





S1 Mini Vivaldi II Owner's Manual

Optional “No Burn” Steam Arm (shown next to stock steam arm)



10 Other LaSpaziale Mini VII Resources

In addition to your Mini VII supplier, current users are an excellent information resource: Check out these internet sites:

<http://www.home-barista.com> – reviews, forums, and lively discussions on all coffee topics

<http://www.coffeegeek.com> - Here you will find lively debate on all things coffee and Mini VII information, including reviews by owners.

<http://www.s1cafe.com/s1v2> – Website devoted solely to the LaSpaziale VII and Mini VII with links to one dedicated to the VI and to the forum below

<http://www.s1cafe.com> - an on-line forum for VI, Mini VII, and Mini VII Mini owners to share information and ask questions.

<http://www.bellabarista.co.uk/pdf/Laspaziales1MiniVivaldicloserlookv2.pdf> - This is actually a detailed review of the VI Mini widely sold outside the United States. However, most of this information is equally applicable to the VII Mini.



S1 Mini Vivaldi II Owner's Manual

11 Quick Setting Guide

Feature	Starting State (ON/STBY)	Key Press	How Long? (Seconds)	How to know when in correct state to configure feature?	Next Button Press	Next Button Press	Exit Strategy
Set Volumetric Dosing for Single Cup	ON	ON/OFF	3	ON/STBY and current set temp lamps blinking	Single Cup Button	Single Cup again when desired amount of water is dispensed	Momentarily Press ON/OFF to exit and save setting
Set Volumetric Dosing for Double Cup					Double Cup Button	Double Cup again when desired amount of water is dispensed	
Set Main Temp					Hot Water	Press and release Hot Water Button until desired temp lamp is On	
Boiler ON/OFF	ON	BOILER	Momentarily	BOILER Lamp switches state	Note: Last boiler state is "remembered" through STBY/ON transitions or Power Fail		
Enhanced Temp Offset	STBY	BOILER	10	On/STBY and BOILER lamps blinking	Double Cup or Single Cup	Double Cup decreases offset by 1C for each press up to -8C. Single Cup increases offset by 1C up to +8C	Momentarily Press ON/OFF to exit and save setting
Extreme Temp Set - Higher	STBY w/ Master Temp =97C	Two Cup	3	94°C (17) and 95°C (18) lights on steady	Hot Water	Hot Water increases temp by 1C for each press up to +3C as indicated by lights	Momentarily press Two Cup to exit and save setting
Extreme Temp Set - Lower	STBY w/ Master Temp =91C	Two Cup	3	94°C (17) and 95°C (18) lights on steady	One Cup	One Cup decreases temp by 1C for each press down to -3C as indicated by lights	Momentarily press Two Cup to exit and save setting