



La Spaziale S1 Vivaldi *Double Boiler Espresso Machine* Owner's Manual

Last Updated on 03/31/2014



S1 Owner's Manual

Table of Contents

1	Feature Overview	1
2	Reference Photos	1
3	Basic Machine Operation	3
3.1	15A or 20 Amp Operation	3
3.2	Initial Installation Before Connecting Power	3
3.3	Turning On and Heating the Machine	4
3.4	Espresso Group Water Temperature Regulation	5
3.4.1	Coarse Temperature Adjustment Mode	5
3.4.2	Fine Temperature Adjustment Mode	5
3.5	Espresso Brewing	6
3.6	Volumetric Dose Programming	7
3.7	Hot Water Delivery	7
3.8	Steam Delivery	7
3.9	Economy / Boiler Operational Modes	8
4	Alarm Handling	10
4.1	Damaged Flow Meter	10
4.2	Damaged Group Temperature Probe	10
4.3	Damaged Boiler Temperature Probe	10
4.4	Damaged Group Heating Element Triac	10
4.5	Damaged Boiler Heating Element Triac	10
4.6	Boiler Automatic Refill System Failure	11
5	Connection Diagrams	12
5.1	Electrical Connection Diagram	12
5.2	Control Board Connection Diagram	13
5.3	Triac Board Connection Diagram	13
5.4	Control Panel Connection Diagram	14
5.5	Wiring Diagram Definitions	14
6	S1 Water Flow Diagram	15
7	Adjustments and Maintenance	16
7.1	External S1 Surface Cleaning	16
7.2	Routine Group Cleaning	16
7.3	Group Pressure Test and Adjustment	17
7.4	Expansion Valve Release Adjustment	17
8	Other LaSpaziale S1 Resources	19
9	Quick Setting Guide	20



S1 Owner's Manual

1 Feature Overview

- Dual Boiler
- Steam Boiler 2.5 liter
- Steam Boiler Element 1250 Watts
- Group Boiler .45 liter
- Group Boiler Element 800 Watts
- Direct Plumbed
- Rotary Pump
- Volumetric Dosing Adjustable Through Touch Pad
- Group Temperature Indicated by LED Display
- Group Temperature Adjustable in 1°C Increments Through Touch Pad
- Electronic Boiler Refill
- Built in Safety Thermostat
- Semi Automatic Hot Water Delivery
- Manual Steam Valve
- Fault Diagnosis Alarms
- Boiler Pressure Gauge
- Two Complete Portafilter handles - Single and Double Baskets
- Extra shower screens, removal wrench, cleaning brush, tamper
- Includes rubber back flush disk
- Color Black, Silver, or Red
- 110 volt
- Available in either 15 amp or 20 amp

2 Reference Photos

These numbered photos will be referenced throughout the document; i.e. (13)

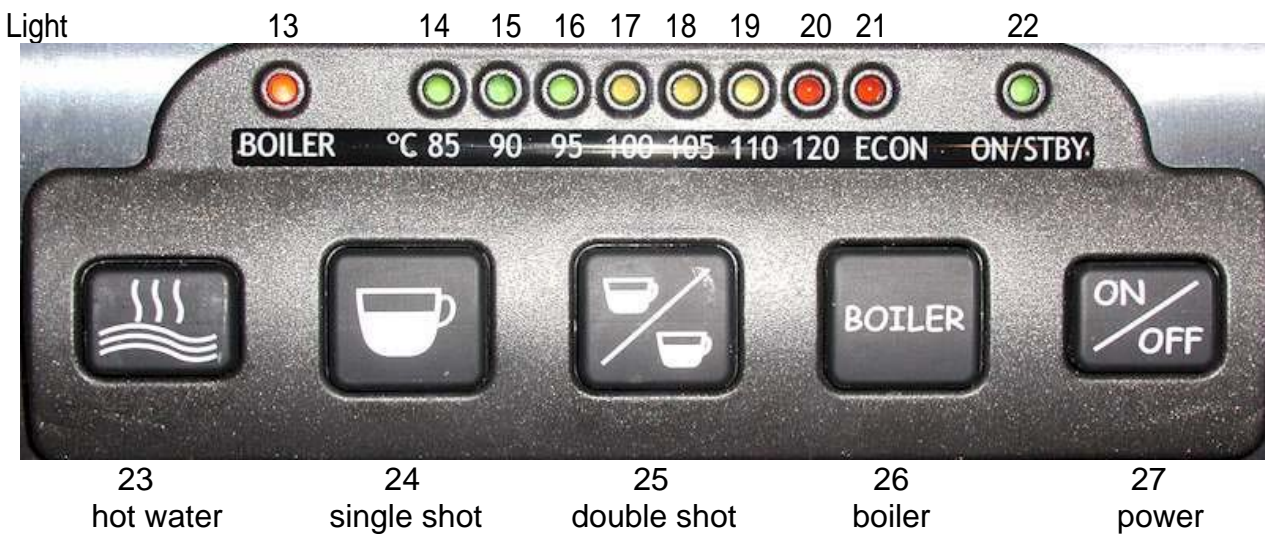

FIGURE 1 – Indicator Lights and Control Buttons



S1 Owner's Manual



Label	Function	Label	Function	Label	Function	Label	Function
1	Drip Tray	8	Warming Tray	15	90°C Lamp	22	On/Standby Lamp
2	Steam Arm	9	Control Panel	16	95°C Lamp	23	Hot Water Button
3	Rubber Feet	10	Group	17	100°C Lamp	24	One Cup Button
4	Boiler Pressure	11	Portafilter Handle	18	105°C Lamp	25	Two Cup Button
5	Side Panels	12	Drip Tray Grate	19	110°C Lamp	26	Boiler Button
6	Steam Knob	13	Boiler Lamp	20	120°C Lamp	27	On/Off Button
7	Splash Panel	14	85°C Lamp	21	Economy Lamp	28	Hot Water Outlet



S1 Owner's Manual

3 Basic Machine Operation

3.1 15A or 20 Amp Operation

The LaSpaziale S1 is available in 15A and 20A versions. In actuality, they are both identical machines. There is an internal switch that selects the operating mode and they have different power cords installed. The power cord is the easiest way to tell which version you have. The 15A S1 has a standard 3-prong AC plug with two parallel blades and a round ground pin. The 20A S1 has a 3-prong with two perpendicular blades and a round ground pin. The 20A version therefore requires a 20A circuit which has a special 20A outlet which accepts the 20A plug.

Most modern kitchens have 20A circuits. However, they often do not use 20A outlets because multiple outlets may be on the same 20A circuit. If you have a 20A circuit with a 20A outlet this most likely means that outlet has its own dedicated 20A circuit and is safe to use with the S1. A 20A circuit with normal 15A outlets probably means that multiple kitchen outlets are on the one 20A circuit. Often this means the refrigerator outlet. 20A S1 owners should contact their electrician if unsure how to proceed.

The internal switch which places the S1 in 15A mode does so by never allowing the group boiler and the steam boiler to operate at the same time. When the thermostats for both boilers try to turn on at the same time, the group boiler always has precedence, and then the steam boiler operates in sequential fashion. A number of 15A S1 owners note that they see little operational effect when running in this mode.

The 20A S1 allows both boilers to operate simultaneously. HOWEVER, it is possible to place the 20A S1 into 15A mode without removing the covers from the machine and flipping the internal mode switch. This is called ECONOMY mode and is described later in this manual.

Economy mode is a great option for those that really want the 20A machine but that do not currently have a 20A circuit. However, this will require swapping out your standard 15A outlet with a 20A outlet. These are readily available from most hardware stores.

3.2 Initial Installation Before Connecting Power

After removing the S1 from its packing carton and setting it on the counter, check for additional installation instructions that may be included.

Tip the S1 on its side. Twist all four rubber feet (3) hand tight as they may vibrate loose during shipping. While performing that task, use a screwdriver to ensure that the four screws on the bottom (two on each side between the rubber feet) which fasten the two side panels (5) to the chassis bottom are tight. These steps will help ensure the quietest possible operation of your S1.

Be sure you connect the included water hose to the threaded water inlet on the bottom of the machine. Proper connection is obvious since there is only one place it can attach. The opposite end of the hose - which connects to the water supply - may require adapters from your local hardware store depending on your specific situation.



S1 Owner's Manual

Contact your S1 vendor for advice if the solution isn't obvious. Also, your S1 vendor may request that you check that your water hardness is below a certain level to ensure long life and trouble free operation. Hardness test strips may be included for this purpose. If your water fails this test, contact your S1 dealer and discuss the available options.

Once water supply is properly attached, turned on, and the desired basket has been inserted into one of the portafilter handles, attach the portafilter to the group. Be sure that the drip tray is installed by sliding it into place at the bottom front of the machine.

3.3 Turning On and Heating the Machine

- 1) Insert the plug into the 110V AC socket, the On/STBY light (22) starts flashing to show the connection to the electric network (Stand-by mode).
- 2) Press the ON / OFF (27) button and keep it pressed for about 3 seconds, the green On/STBY light (22) changes from flashing to steady indicating the machine is ON. At the same time the lights from (14) to (21) turn on steadily for about a second (indicating power on test mode).
- 3) The light corresponding to the set temperature starts flashing to indicate that the group is heating and the automatic boiler refill starts until the water level preset by the manufacturer is reached.
- 4) Once the filling process is finished, the boiler light (13) starts flashing to indicate that the boiler is heating. However, after first switching on, the boiler doesn't work until the group has reached the set temperature.
- 5) Fasten the portafilter handle (11) to the brewing group (10).
- 6) Wait until the set temperature is reached, by checking that the lights on the control panel (9) gradually turn on as the temperature rises. The visualization starts as soon as the temperature reaches 85°C (turning on of light 14) and continues until the machine has reached its operating temperature (light from flashing to fixed).
- 7) When the group has reached the set temperature, the boiler heating starts (boiler light (13) flashing), once it reaches the set temperature the light becomes fixed.
- 8) Every time the group temperature or the boiler temperature drops under the set value, the respective light starts flashing (heating phase) until the set temperature is reached.
- 9) The machine is now ready.



S1 Owner's Manual

WARNING!!

To activate and deactivate the boiler mode press the "BOILER" (26) button. Every time you turn on the machine, the boiler is in service.

When the boiler is turned off, it is impossible to use hot water for infusions or steam delivery.

The machine can also operate in the economy mode (see relative paragraph).

3.4 Espresso Group Water Temperature Regulation

3.4.1 Coarse Temperature Adjustment Mode

1. When the machine is On, press the button ON//OFF (27) and keep it pressed for 3 seconds, the control light (22) and the one concerning the set temperature start flashing. For example, if the set temperature is 105°C, light (18) starts flashing.
2. In order to change the operating temperature, press and release the hot water delivery button (23); every press of the button corresponds an increase of the temperature of 5°C (with the flashing of the corresponding light). When the maximum temperature of 120°C (I20) is reached, the selection restarts from the minimum temperature of 85°C (14) (cyclic mode).
3. Once you choose the desired temperature, in order to lock in this value, press the ON/OFF (27) button, the machine will then go back to its normal functioning.

The value of the operating temperature of the machine is easily changed in order to improve the final result in the cup depending on the coffee blend used and the user's personal preference.

3.4.2 Fine Temperature Adjustment Mode

Once you set this coarse temperature control to 85°C, 90°C, 95°C, 100°C, 105°C, 110°C, or 120°C as your master temperature, you can enter the fine temperature control mode which allows you to adjust the temperature relative to the master temperature in 1°C increments up or down as far as $\pm 3^\circ\text{C}$.

Here are the steps required to successfully program in $\pm 1^\circ\text{C}$ increments:

(**BOLD** = lamps, **Reverse** = buttons)

1. The S1 must be in Standby mode; i.e. the green **ON/STBY** (22) lamp is blinking. If not already in this mode, momentarily press the **ON/OFF** (27) button.
2. Press and hold the **Two Cup** (25) button in for 3 seconds until both the yellow lamps over **100** (17) and **105** (18) are steadily lit. This condition indicates an offset of 0°C from the master temperature setting. (If any of the green lamps, the other yellow lamp, or the red lamps are lit at this time, a non-zero offset has



S1 Owner's Manual

- previously been programmed.)
3. To increase the temperature, press the **BOILER** (13) button. The first press lights the yellow lamp over **110** (19) which indicates +1°C. A 2nd press also lights the red lamp over **120** (20) which indicates +2°C. A 3rd press also lights the red lamp over **ECON** (21) which indicates +3°C. A 4th press of the **BOILER** (13) button extinguishes all three lamps indicating that the machine has cycled back to 0°C offset from the master setting.
 4. To decrease the temperature, press the **One Cup** (23) button. The first press lights the green lamp over **95** (16) which indicates -1°C. A 2nd press also lights the green lamp over **90** (15) which indicates -2°C. A 3rd press also lights the green lamp over **85** (14) which indicates -3°C. A 4th press of the **One Cup** (24) button extinguishes all three green lamps indicating that the machine has cycled back to 0°C offset from the master setting.
 5. When finished, press the **Two Cup** (25) button until the lamps extinguish. You will be back in Standby mode with only the **ON/STBY** (22) lamp blinking. At this time, your setting is memorized and will remain until you repeat the above procedure to change it.

If, for example, your master temperature setting before entering the fine temperature control mode is 95°C and you press the **One Cup** (24) button until all three green lamps are lit, the water temperature is programmed to 92°C. When back in normal operational mode with the green 95°C lamp lit steadily, the water temperature will actually be 92°C.

NOTE: The master temperature setting and the fine temperature setting are completely independent. If you have set the temperature to 92°C, as in the above example, and later decide you want the temperature to be 100°C, changing the master setting to 100°C will result in 97°C water temperature because the fine temperature setting is still at -3°C.

3.5 Espresso Brewing

1. Unfasten the portafilter handle (11) from the brewing group (10) and insert the filter for one or two cups.
2. Fill it with ground coffee, making sure not to leave coffee powder on the upper edge of the portafilter handle (11), and press it with the suitable coffee tamper provided.
3. Firmly attach the portafilter handle (11) to the brewing group (10).
4. Place one or two cups under the portafilter handle (11).
5. Press the button corresponding to one cup (24) if you want to make one coffee or two cups (25) to start the delivery. Once the desired quantity of coffee programmed is reached, the delivery automatically stops.



S1 Owner's Manual

3.6 Volumetric Dose Programming

The programmable volumetric dosing feature allows programming of the single shot (24) and double shot (25) buttons to dispense whatever quantities of espresso the user desires. Their use for single shot and double shot quantities is merely a suggestion. Many users only pull double shots and program the double shot button for 1.5-2.0oz for that purpose. Then they program the "single shot" button for a larger amount for use in flushing the portafilter basket and/or the group between shots. The beauty of the programmable dosing feature is that the machine owner can be creative. The following are the instructions for programming each button assuming they are being used for single and double shots.

1. With the machine on, press the ON//OFF (27) button and keep it pressed for about 3 seconds; the control light (22) and the one indicating the set temperature start flashing.
2. Insert the 1 cup basket into the portafilter handle (11) and fill it with 7-8g of ground coffee making sure not to leave coffee powder on the upper edge of the portafilter handle, and press it with the included plastic tamper or, more optimally, a high quality 53mm coffee tamper.
3. Fasten the portafilter handle (11) to the brewing group (10), placing a cup under the portafilter handle.
4. By pressing the one cup button (24) the delivery starts and the lights 14-15-16 turn on to show that the one shot espresso dose is being programmed.
5. When the coffee inside the cup has reached the desired quantity, again press the button (24) to stop the delivery.
6. You automatically return to the initial visualization.
7. Repeat the previous steps above using the 2 cup button (25) making sure you change the filter inside the portafilter handle (11) to the double shot basket and fill it with 14-16g of espresso first.

3.7 Hot Water Delivery

(only possible with the boiler turned on, light 13 on)

1. Place the pitcher below the hot water output (28):
2. Press the hot water delivery push-button (23).
3. The hot water delivery starts (at this stage the pump is working).
4. Once the desired quantity is reached, stop the delivery by pressing the same button (23)

3.8 Steam Delivery

(only possible with the boiler turned on, light 13 turned on)

1. Insert the steam wand (2) in the pitcher containing the drink to be heated.
2. Turn the steam knob (6) counter-clockwise, regulating the steam flow according to the need.



S1 Owner's Manual

3. At the end of the heating phase of the drink, stop the steam delivery by turning the steam knob (6) clockwise
4. Remove the pitcher from the steam wand (2) and wipe the steam wand and tip immediately with a clean, damp sponge in order to remove all residue of the heated drink.

WARNING!!

Do not turn the steam knob (6) before placing the steam wand (2) inside the pitcher, in order to avoid burns.

3.9 Economy / Boiler Operational Modes

BOLD = Lamps, **Reverse** = Buttons

On the 20Amp models of the LaSpaziale S1, the **Boiler** button performs two roles:

1. Turning the Steam boiler on and off
2. Entry and exit of Economy mode

There are three possible operational modes of the two boilers in the La Spaziale S1 20A model:

1. Both boilers are completely independent, turning on and off according to the needs of each. Both can be on at the same time. This is the default mode.
2. The **Boiler** button can toggle the Boiler on and off. This mode is useful for those that only drink espresso and do not need steam or hot water and want to conserve energy.
3. The **Boiler** button can also be used to switch in and out of Economy mode. In this mode only one boiler can be on at a time. The S1 automatically controls which is on according to demand with preference going to the group boiler. This is useful for those owning the 20A model but lacking a 20A circuit.



S1 Owner's Manual

Turning the Steam/Hot Water Boiler On and Off

1. The S1 must be in ON mode, not Standby for all operations below.
2. Momentarily press the **Boiler** button
3. The **Boiler** lamp turns off. Neither steam nor hot water is available.
Note: if you turn the S1 Off then On again, or if power is removed and restored to the S1, the Boiler returns to the On state.
4. Momentarily press the **Boiler** button again.
5. The **Boiler** lamp is on (or blinking). Steam and hot water are available.

Turning Economy Mode On and Off

1. The S1 must be in ON mode, not Standby for all operations below.
2. Press the **Boiler** button for 10 seconds until the **ECON** lamp illuminates.
Economy mode is now active.
Note: if you turn the S1 Off and On again or if power is removed and restored to the S1, Economy mode remains active until you perform step 4, below.
3. While in Economy mode you can momentarily press the **Boiler** button to completely turn off the boiler. Another momentary press returns you to Economy mode.
4. To exit Economy mode, press and hold the **Boiler** button for 10 seconds until the **ECON** lamp is extinguished.



S1 Owner's Manual

4 Alarm Handling

The S1 uses computerized sensors to robustly handle S1 device malfunctions. There are two types of alarms the S1 can generate:

Blocking Alarms – these are the most serious. The S1 will not function when one of these alarms occurs

Non-Blocking Alarms – These are informational only and, while they do represent an error condition, the machine will continue to function.

4.1 Damaged Flow Meter

When the flow meter isn't working properly or when the coffee grind is too fine, this is indicated by the turning on of the lights 14-15-16; if you are making one coffee dose, and the lights 17-18-19 if you are making two coffee doses. This is a non-blocking alarm. This alarm is actually useful when back flushing as an indication of when to turn off the pump and allow the 3-way valve to operate.

4.2 Damaged Group Temperature Probe

This alarm is a blocking one, and occurs when the temperature probe of the group is in short circuit (temperature $>145^{\circ}\text{C}$) or is interrupted (temperature $<60^{\circ}\text{C}$). The lights 20-21 turn on.

4.3 Damaged Boiler Temperature Probe

(only with the boiler turned on)

This is not a blocking alarm and occurs when the temperature probe of the boiler is in short circuit (temperature $>145^{\circ}\text{C}$) or is interrupted (temperature $<60^{\circ}\text{C}$). The lights 19-20-21 turn on.

4.4 Damaged Group Heating Element Triac

This alarm is a blocking one, and occurs when the group triac always remains in conduction (temperature $>140^{\circ}\text{C}$). The lights 20-21 are flashing.

4.5 Damaged Boiler Heating Element Triac

(only with the boiler turned on)

This alarm is a blocking one, and occurs when the boiler triac always remains in conduction (temperature $>140^{\circ}\text{C}$). The lights 19-20-21 are flashing.



S1 Owner's Manual

4.6 Boiler Automatic Refill System Failure

(only with the boiler turned on)

This is a blocking alarm which is signaled by blinking of the **Boiler** (13) light. If the pump runs for more than 1 minute attempting to refill the boiler without the controller circuit receiving a boiler full signal, this alarm is triggered.

This alarm can be temporarily cancelled by pressing the **BOILER** (26) button to turn off the boiler. The S1 can be operated with the steam boiler off until repairs to the boiler function occur.

Once the reason for the alarm is repaired – usually a total or partial water line blockage – it is necessary to unplug the machine and then plug it back in to clear the alarm.

5 Connection Diagrams

5.1 Electrical Connection Diagram

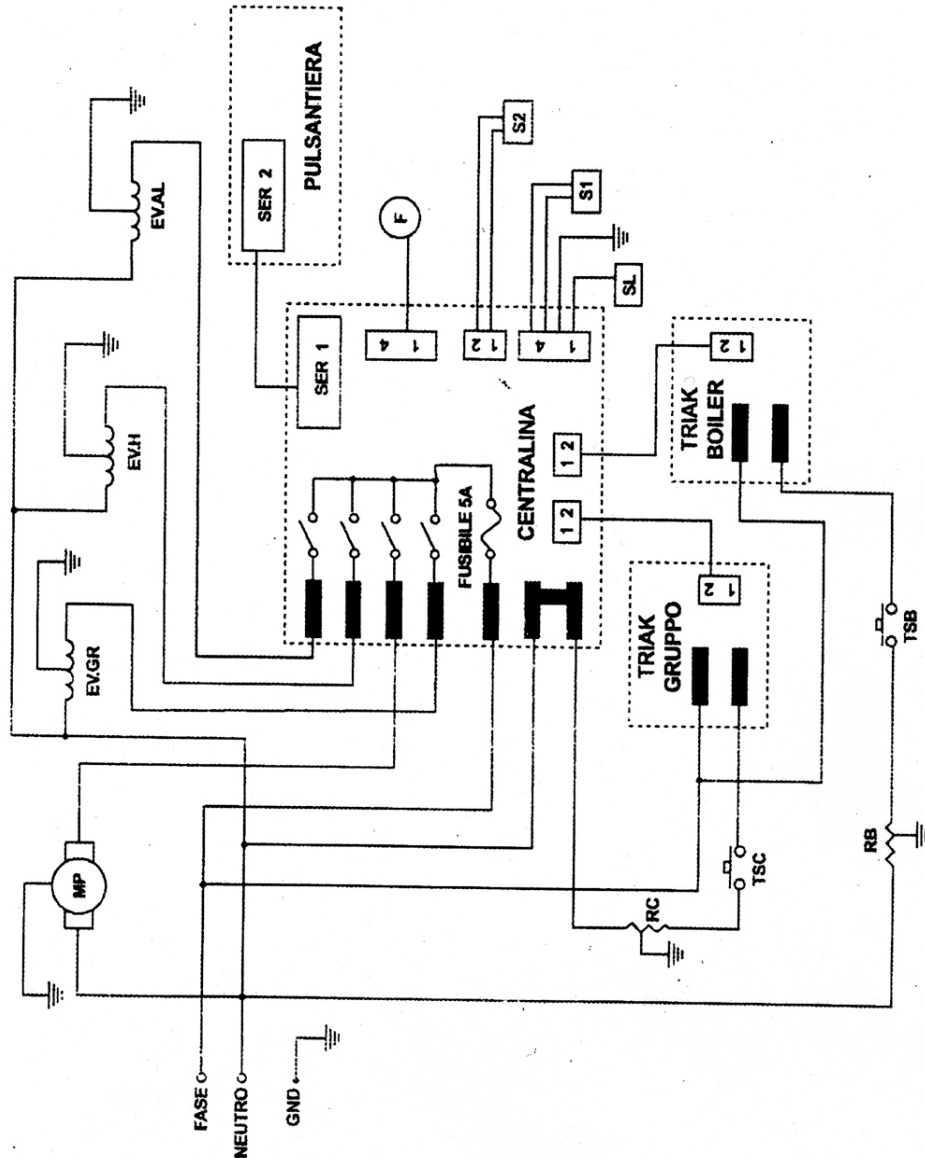

5.2 Control Board Connection Diagram

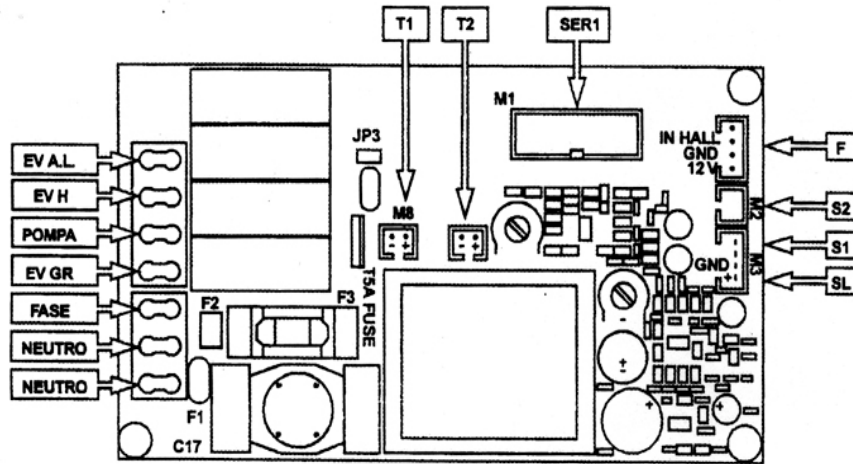

Early versions of the S1 used a jumper on the above board (JP3) to switch between 15A and 20A mode. J3 Jumpered = 15A, No Jumper = 20A. Newer S1 have the above board enclosed in a plastic case with a switch on the case used to change modes.

5.3 Triac Board Connection Diagram

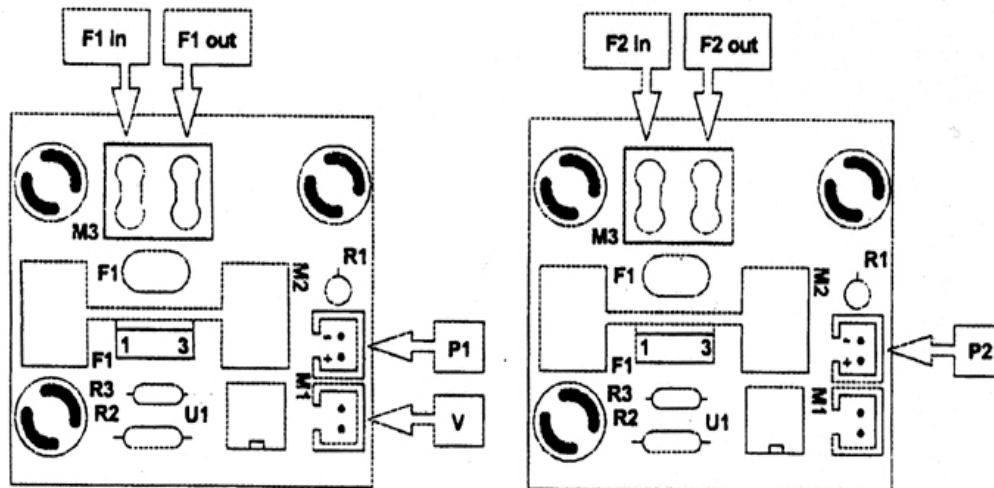

BOILER TRIAC BD

GROUP TRIAC BD

(Cooling Fan is below this board and runs only when boiler is heating)

5.4 Control Panel Connection Diagram

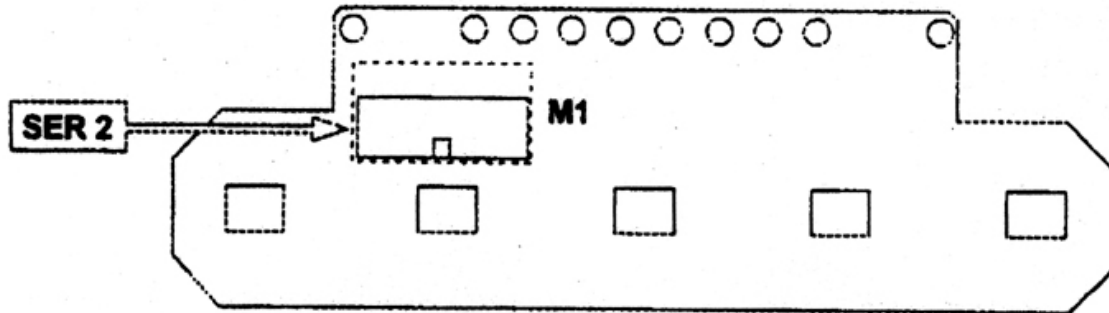

5.5 Wiring Diagram Definitions

EV GR	Coffee brewing group electrovalve
EV H	Hot water delivery electrovalve
EV AL	Automatic refill system electrovalve
T1	Connection on control board of the triac that feeds the boiler heating element
T2	Connection on control board of the triac that feeds the group heating element
P1	Connection of the control board on the triac that feeds the boiler heating element
P2	Connection of the control board on the triac that feeds the group heating element
SER 1	Connection control panel on control board
SER 2	Connection control board on control panel
F	Flow meter
Flin	Phase inlet into the triac that feeds the boiler heating element
Flout	Phase outlet from the triac that feeds the boiler heating element
F2in	Phase inlet into the triac that feeds the group heating element
F2out	Phase outlet from the triac that feeds the group heating element
S1	Boiler temperature probe
S2	Brewing group temperature probe
SL	Boiler water level control
V	Ventilator connection
MP	Motor pump
RC	Heating element brewing group
TSC	Safety thermostat for brewing group heating element
RB	Boiler heating element
TSB	Safety thermostat for boiler heating element



S1 Owner's Manual

6 S1 Water Flow Diagram

The information below is provided strictly as a reference for S1 owners who are curious about the function of their S1 Dual Boiler design.

LaSpaziale S1 Water Flow Diagram

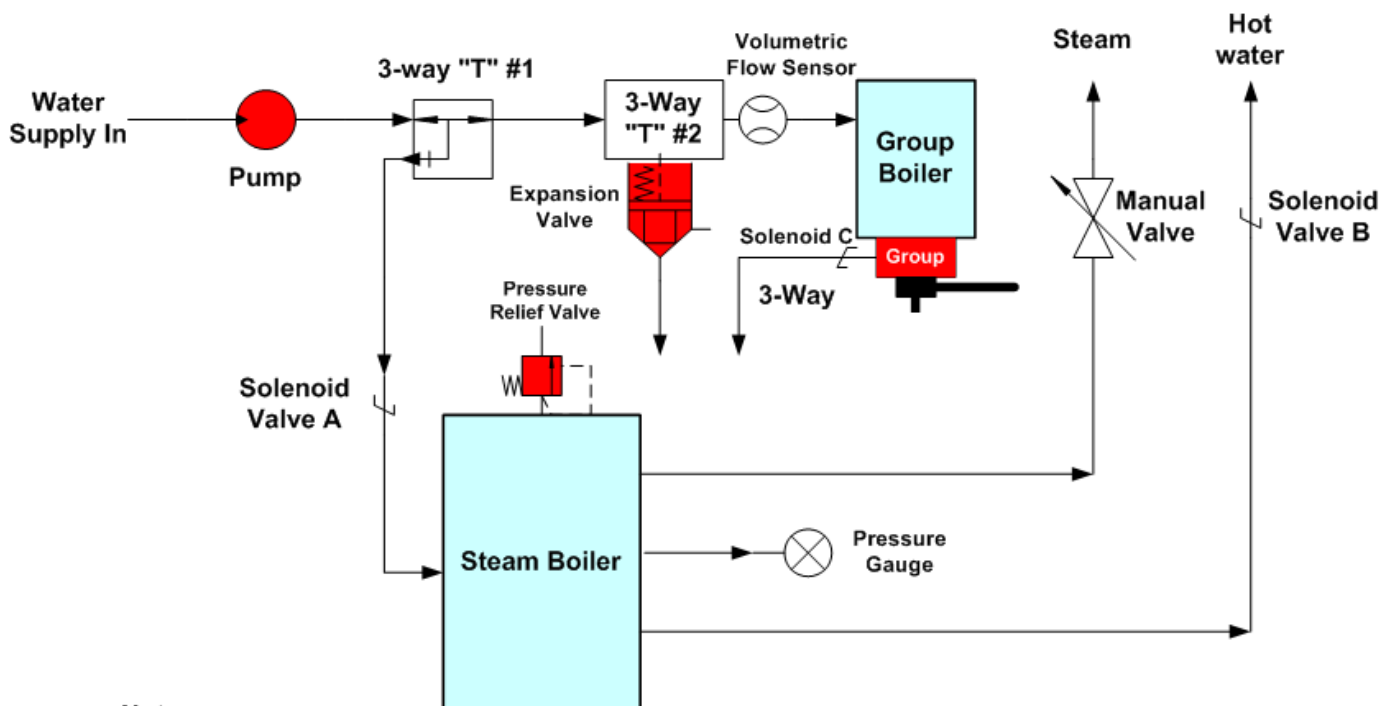

Notes:

- 1) The pump does not block water flow when it is not running. When the pump is off, street water pressure remains at the pump outlet. This means that water pressure is constantly applied through 3-way T #1, through 3-Way T #2, and into the group boiler. However, refill of the steam boiler requires activation of Solenoid Valve A which occurs in response to the water level sensor inside the Steam Boiler.
- 2) A properly adjusted expansion valve should open >12bar. This situation might arise if the pump pressure is too high and has insufficient flow through the group or if the group boiler pressure gets too high even when the pump is off.
- 3) The two Three Way "T" connectors allow water to flow into one port and out the other two much like the "Y" connectors used on garden hoses to connect two hoses to one spigot.
- 4) The Volumetric Flow Sensor sends a signal to the computer controller board so it can sense the pre-programmed flow to the group and shut off the pump when the correct amount of water has been delivered.



S1 Owner's Manual

7 Adjustments and Maintenance

7.1 External S1 Surface Cleaning

Use a damp sponge and wipe dry with a soft cloth. Alternately, window cleaner wiped off with a dry soft cloth works well.

7.2 Routine Group Cleaning

The extra pair of shower screens was not included with your S1 so you'd have an extra set. They are included as part of LaSpaziale's recommended cleaning regimen which is targeted at light commercial use where there is no time for a complete detergent based back flush routine. The reason for LaSpaziale's double shower screen arrangement is to trap grounds between the screens so that the 3-way valve rarely, if ever, needs a detergent cleaning.

- With the S1 on and fully heated, use the included key wrench to remove the shower screen bolt.
- Drop out the two screens and the dispersion disk.
- Use the included plastic handled wire brush to quickly scrub the group head while water is running through the group to flush out the particles. (This is why the long handled brush - to keep your hands away from hot water.)
- Also, give the dispersion disk a quick scrub.
- Reassemble using the other set of screens.
- Soak the original set of screens in Cafiza or similar detergent, scrub, rinse, and put away for next time.

NOTE: The following are advanced maintenance and adjustment procedures. Do not perform them without the proper tools and confidence that you can do them properly. When in doubt always contact your S1 vendor first.



S1 Owner's Manual

7.3 Group Pressure Test and Adjustment

This adjustment and the one covered in the next section require a portafilter pressure gauge such as the one pictured below which comes mounted on a dedicated portafilter. Your S1 dealer should be able to sell you this one or you can get generic gauges which screw onto your own portafilter spout.

Removal of the chrome panel behind the portafilter is required. This is the panel through which protrudes the boiler pressure gauge. Use a large Phillips screwdriver to remove the two screws adjacent to the numbers (5) on the diagram on page 2. Then remove the panel. Attach the pressure gauge to the portafilter. The adjustment screws are located just above the letter "E" in the diagram below. First, loosen the lock nut (14mm wrench). Press the One Cup (24) or Two Cup (25) button and wait for the gauge pressure to stabilize. Most users prefer group pressure in the range 8.2-9.0 bar. Turning the adjuster nut (10mm wrench) counter-clockwise lowers the pressure, turning it clockwise increases the pressure. When it is set to your preferred pressure, tighten the lock nut and recheck. Then reattach the front panel. Should your water supply pressure change significantly, readjustment will be required as the rotary pump supplies an adjustable boost to the supply pressure. However, if you add an in-line pressure regulator to the water supply line this should not be required. If your water supply pressure is higher than 30psi, a water pressure regulator can also reduce or eliminate expansion valve drips.

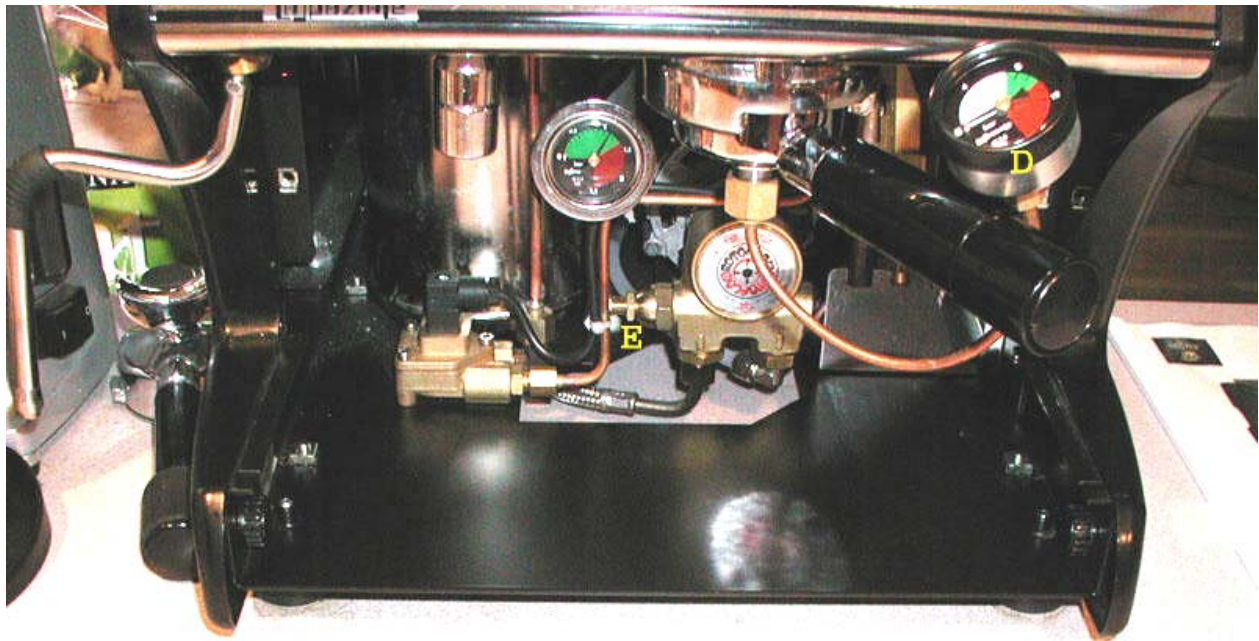

7.4 Expansion Valve Release Adjustment

This procedure starts by removing the chrome front panel as in the above procedure and also requires the portafilter pressure gauge.

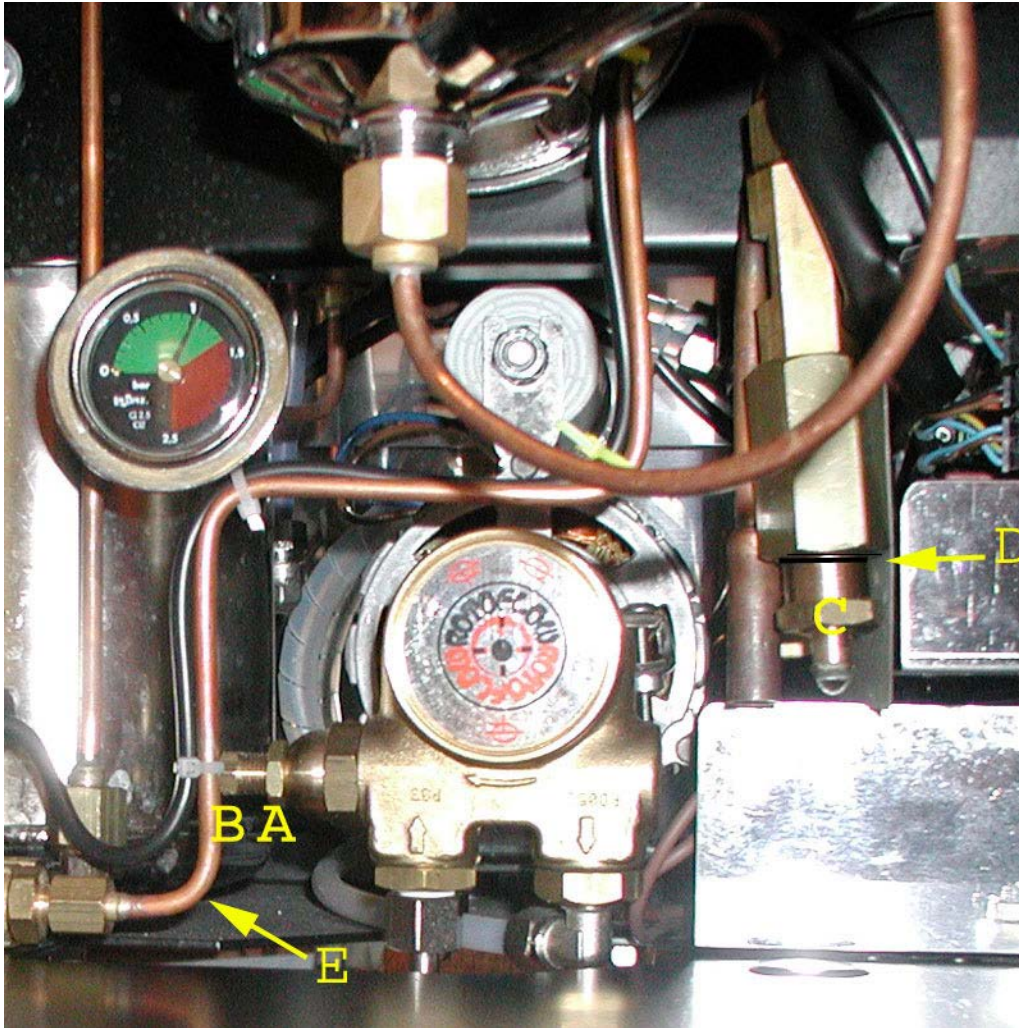

1. Adjust the group pressure to 12.5 bar per the following instructions:
 - a) Loosen lock nut "A" using the 14mm wrench
 - b) Tighten nut "B" 1-2 turns using the 10mm wrench
 - c) Turn on pump until pressure on the PF gauge stabilizes
 - d) Repeat steps b & c until pressure reads 12.5 bar
2. The expansion valve "C" should open at 12.5 bar
3. If no water is dripping or running from the tube below nut "C" at 12.5 bar the expansion valve is set too high. Use the 21mm socket to loosen nut "C" (rotate counter-clockwise as viewed from the bottom of this valve) until the valve just opens when running the pump as the pressure reaches 12.5 bar.
4. If water is pouring out of tube below "C" before the pressure hits 12.5 bar, use the 21mm socket to tighten nut "C" (rotate clockwise and viewed from the bottom of this valve) until the valve is just opening at this pressure. If you back off the PF pressure



S1 Owner's Manual

to 12 bar all dripping should stop - though it may take a minute or two for residual moisture to drip out.

5. Once you are convinced that the expansion valve is properly calibrated, readjust the rotary pump pressure by unscrewing "B" to reach your preferred pressure - normally in the range of 8.2 to 9.0 bar. Then tighten lock nut "A".

Notes:

- 1) Make small adjustments, then turn the pump on and check. Don't attempt any of these adjustments while the pump is on.
- 2) The copper tube denoted by the letter "D" exits the flow gauge here and then attaches to the top of the Expansion valve.
- 3) The term expansion valve is somewhat of a misnomer as this device is really the overpressure valve for the group boiler. The steam boiler has its own dedicated valve.

8 Other LaSpaziale S1 Resources

In addition to your S1 supplier, current users are an excellent information resource: Check out these internet sites:

Alt.coffee: Many S1 users check in and contribute to this Usenet group. You can also "Google" the alt.coffee archives for answers to S1 or virtually any other coffee related question.

<http://www.coffeegeek.com> - Here you will find lively debate on all things coffee and S1 information, including reviews by owners.

<http://s1.rimpo.org> – one owner's website devoted solely to the S1

<http://www.rimpo.org/wforum/> - an on-line forum for S1 users to share information and ask questions.



S1 Owner's Manual

9 Quick Setting Guide

La Spaziale S1 Vivendi

Dose Setting (to program single or double cup button)

With the machine on, hold the **On/Off** button til the **On/Stby** light flashes. Fill PF with coffee. Press the **Single Cup** or **Double Cup** button. Press the same button again when proper volume achieved. Momentarily press the **On/Off** button to save setting.

Master Temp Setting

With machine on, hold **On/Off** button til **On/Stby** & current **Temp** lamps start flashing. Press the **Hot Water** button to cycle to the next **Temp**. When the desired **Temp** lamp is lit, press the **On/Off** button to save.

Incremental Temp Control (up to $\pm 3^{\circ}\text{C}$)

Press **On/Off** button til **On/Stby** light blinks. Press **Two Cup** for 3 sec. To decrease temp press **One Cup** button. 1 green= -1°C , 2 green= -2°C , 3 green= -3°C . Just two yellow lamps= 0°C . To increase temp press **Boiler** button. 1 yellow= $+1^{\circ}\text{C}$, 1 yellow+1 red= $+2^{\circ}\text{C}$, 1yellow+2 red= $+3^{\circ}\text{C}$. Press **Two Cup** button until lamps go out & **On/Stby** blinking.